



Wiring Instructions 92 and 93 Series 16 Function Receivers



1

Identify the components

Parts included in your kit.

- 1 x Receiver
- 1 x Transmitter complete with
 - 1 x Lo-Cover
 - 1 x Lanyard

Items not shown
 3 x Cable Glands
 1 x 9863 External Aerial
 These instructions
 (6 pages)



2

IDENTIFY POWER CONNECTION POINT AND ISOLATE SUPPLY

Remove fuse



or Disconnect Battery



3



CAUTION

TAKE TIME TO LOCATE THE BEST POSITION

If necessary power the Receiver and move it around the vehicle until the required performance is achieved. Operate the Transmitter and observe the Receiver internal LED's.

Mount as **HIGH** as possible
AVOID surfaces with **HEAVY VIBRATION**
AVOID DIRECT SPRAY from wheels
 In a **HOT CLIMATE** fit in a **SHADED** position
 Cable gland should face **DOWN** or **BACK**

4

MOUNT RECEIVER

1

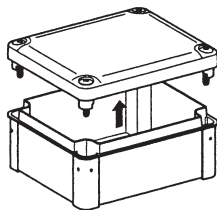

2

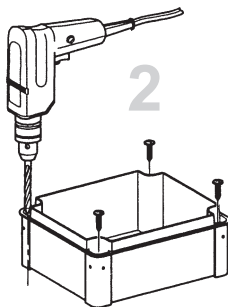

3

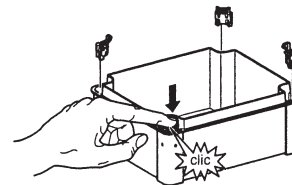

4

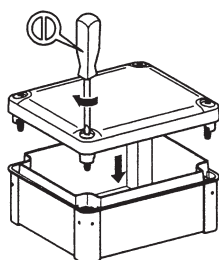

5

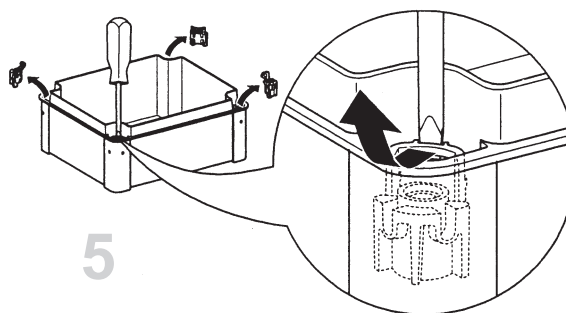

5

IDENTIFY THE CONNECTING PLUGS ON THE PCB

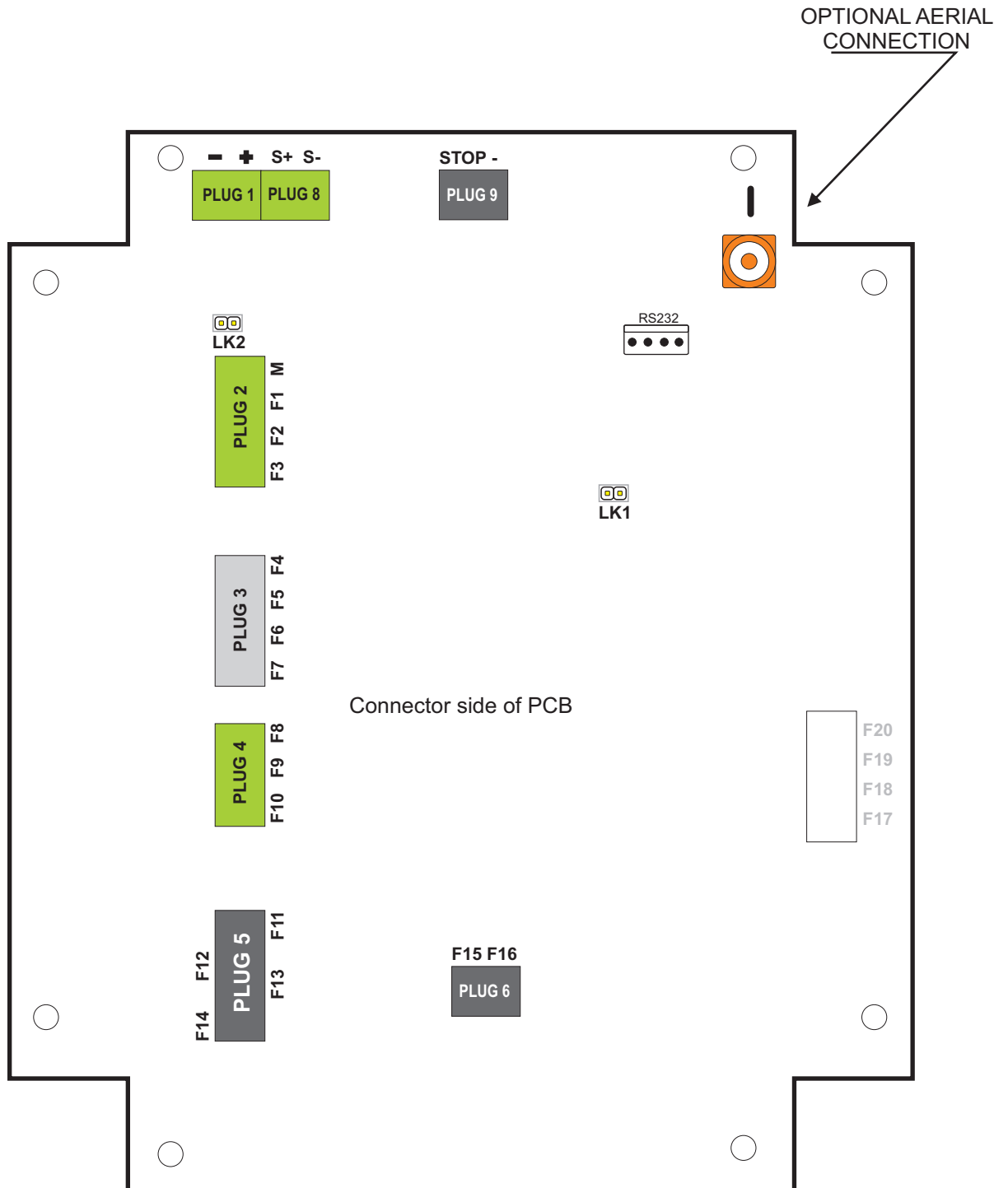

IMPORTANT

ENSURE THAT THE GAUGE OF WIRE USED CAN CARRY 15 AMPS (THIS IS THE MAXIMUM TOTAL CURRENT THAT LODAR CAN SWITCH) OVER THE DISTANCE FROM THE BATTERY WITH NO SIGNIFICANT VOLTS DROP!



SAFETY FEATURE

The Receiver switches itself off after 30 minutes of inactivity.



NOTE

The STOP input can be used for OVERLOAD or OVER-TEMPERATURE etc. If the chassis is GROUND, then a return wire is not required.

6

Make your connections as detailed below

RECORD WIRE COLOURS BELOW

POWER + MASTER

PLUG 1
(GREEN)



+ 12 / 24 VOLT COMMON SUPPLY
- GROUND

OUTPUTS

PLUG 2
(GREEN)



MASTER OUTPUT
FUNCTION 1
FUNCTION 2
FUNCTION 3

PLUG 3
(GREY)

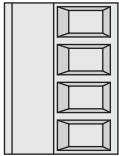

FUNCTION 4
FUNCTION 5
FUNCTION 6
FUNCTION 7

PLUG 4
(GREEN)



FUNCTION 8
FUNCTION 9
FUNCTION 10

PLUG 5
(BLACK)



FUNCTION 11
FUNCTION 12
FUNCTION 13
FUNCTION 14

PLUG 6
(BLACK)



FUNCTION 15
FUNCTION 16

Safety Solenoid etc.

PLUG 8
(GREEN)



S+
S-

STOP Connections

PLUG 9
(BLACK)



STOP
0 Volts

LK1



JUMPER may be RED or BLUE

LK1, when bridged causes the Master Output to be **Parallel**

LK2



LK2, when bridged causes the Master Output to be **Continuous**

JUMPER MUST BE FITTED FOR LODAR TO WORK

POWER DOWN RECEIVER BEFORE MAKING CHANGES

7

FINAL CHECK

⚠ ALL ITEMS IMPORTANT

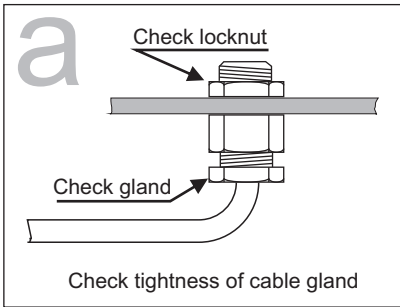

b

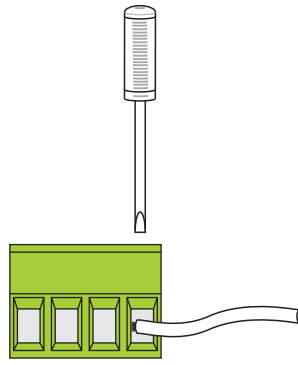

Check all connector screws for tightness even the ones that are not used as these could cause a short circuit if they vibrate out of the connector

c

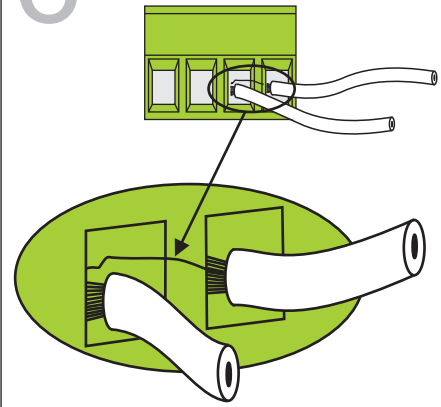

Stray strands of wire can cause a short circuit

d

CONNECTOR BLOCK

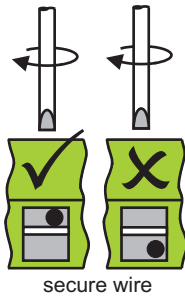

e

IT IS NOW SAFE TO RECONNECT THE POWER SUPPLY

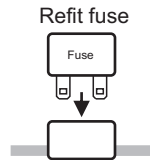

or Connect Battery

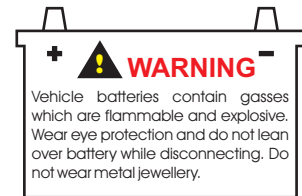

Transmitter Part Number 92216TX or 93216TX

STOP Button switches off the Receiver and the keypad function buttons

L.E.D. Blinks when Transmitter and Receiver are active.

L.E.D. ON when a Transmitter Button is pressed.

L.E.D. FLASHES when batteries are low and a Button is pressed



SAFETY FEATURE

The Transmitter automatically transmits a **STOP** signal after 30 minutes; this de-activates the Receiver and the Transmitter keypad.

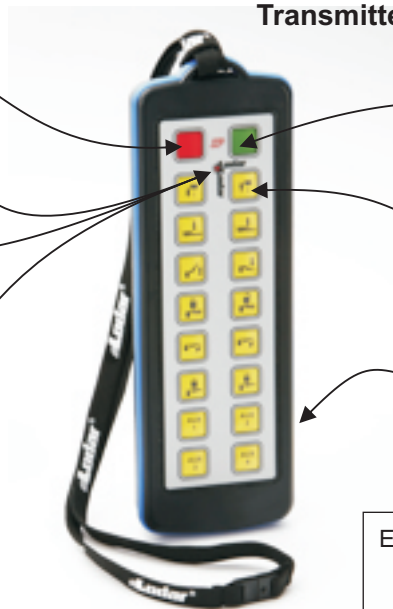

RESET Button activates the Receiver and the keypad function buttons

Function 2 Button

4 Release Screws for Battery Compartment at rear.

4 x AAA batteries

Effective working range up to a distance of 60 metres (200 feet) 92 Series and 300 metres (1000ft) 93 Series.



Your product is marked with this symbol. It means that used electrical and electronic products should not be mixed with general household waste. There is a separate collection system for these products.

In the EEC - Please contact your National Distributor (see www.lodar.com for this information) who will inform you about the take-back of the product. You might be charged for the costs arising from the take-back and recycling. Small products might be taken back by your local collection facilities.

Outside the EEC - If you wish to discard this product please contact your local authorities and ask for the correct method of disposal

Lodar 9100 Series is guaranteed for a period of 24 months from the date of purchase, as long as it is wired in accordance with our instructions, and that the equipment is fitted with an isolation system to shut off all power in event of an emergency.

LED's indicate the following

LED marked "5V" indicates power supply for control circuits is OK

LED marked "SET" indicates the system active.

LED marked "Fault" indicates an overload is present; the system cannot be reset until overload is removed.

This LED blinks for 20 seconds when the system is initially powered. A replacement Transmitter (or Keypad or Wired Remote) has to be registered during this 20 second period.

LED's marked F1 to F16 and M (and optional MC) when ON indicate an output to that function

(MC is an extra Continuous Master output)

LED description and location

Description	Location
+ 5 Volts	= +5
Fault	= Fault
SET	= Set
Master	= M
Function 1	= F1
Function 2	= F2
Function 3	= F3
Function 4	= F4
Function 5	= F5
Function 6	= F6
Function 7	= F7
Function 8	= F8
Function 9	= F9
Function 10	= F10
Function 11	= F11
Function 12	= F12
Function 13	= F13
Function 14	= F14
Function 15	= F15
Function 16	= F16

FAULT CHECK

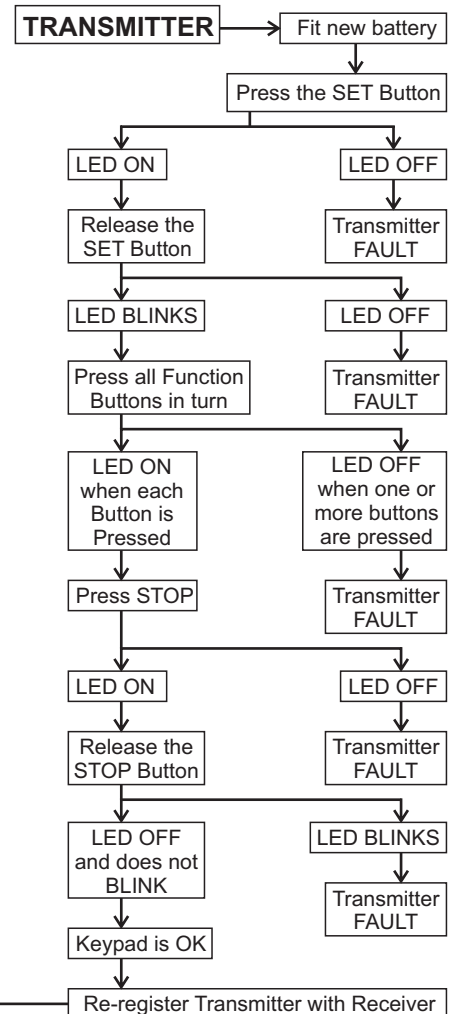
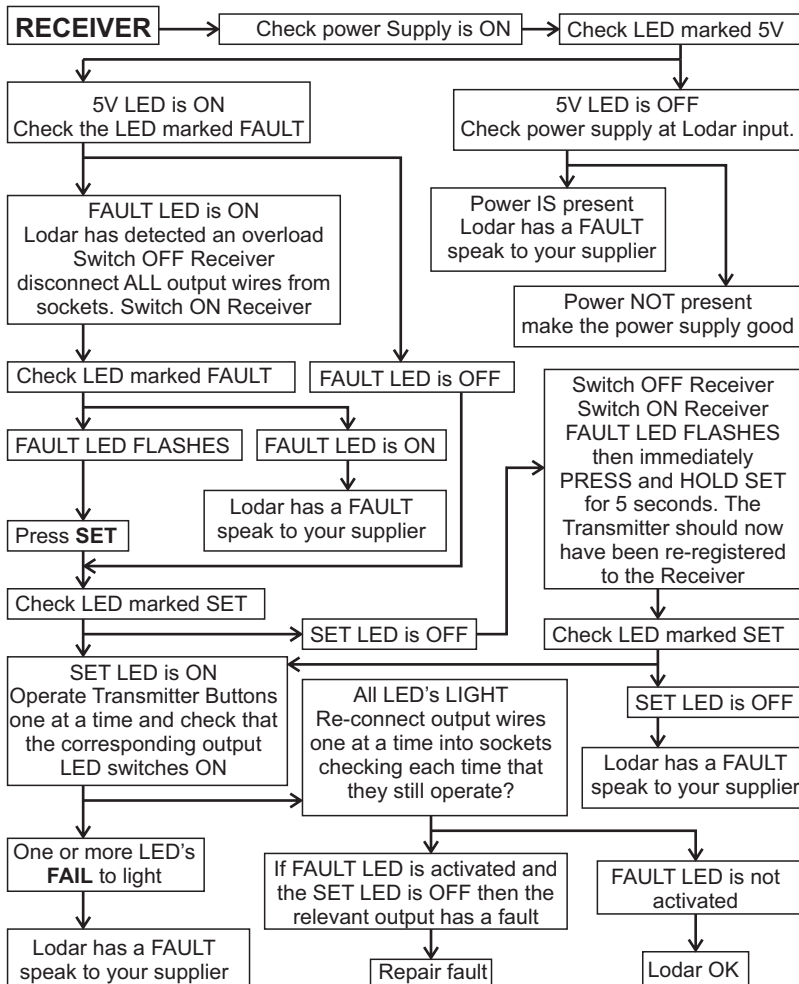

TRANSMITTER REGISTRATION - IF YOUR LODAR DOES NOT WORK TRY THIS FIRST

During transit security scanning can sometimes cause a Receiver to loose the Transmitter registration in its memory.

To register a Transmitter to Receiver.

- Step 1. Switch OFF or DISCONNECT the power to the Receiver.
- Step 2. Switch ON or Reconnect the power to the Receiver.
This opens a 20 second registration window in the Receiver processor.
If you are looking at the Receiver PCB the Fault LED Flashes.
- Step 3. Immediately PRESS and HOLD the Transmitter Reset Button (The Green Button) for a minimum of 10 seconds during this 20 second window.
When the Transmitter is Registered the Fault LED goes out, and the Set LED comes on.
Your Transmitter is now operating the Receiver.

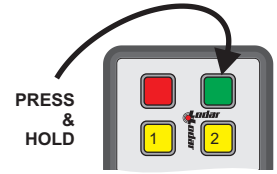

Skidmore 4WD Limited Warranty for LODAR Valid Worldwide

Limited Warranty.

Skidmore 4wd Ltd ("Seller") warrants to the original buyer ("You") all parts and components to be free of faults in materials workmanship for a period of two (2) years from provable date of purchase. Any Lodar product that is faulty will be repaired or replaced without charge to you, upon compliance with these procedures. The Warranties set forth herein are exclusive and in lieu of all other Warranties, whether oral or written, express or implied.

Limited Warranty Performance Procedure

Upon discovery of a faulty Lodar product, you shall notify the Seller in writing, at his factory or at any authorised distributor, details of the said fault and mail, or otherwise ship the faulty Lodar product, postage or other carriage prepaid. Repairs or replacements by the Seller under this Limited Warranty will normally be accomplished within fifteen (15) working days after the receipt of the faulty Lodar product. The Seller, or its authorised distributor, may make reasonable charges for repairs that are not covered by this Limited Warranty

Warranty and Remedy Limitations and Exclusions

The following exclusions or limitations of Warranties and limitations of remedies shall be expressly applicable:

Express Warranties. Seller warrants that the Lodar is as described in the "Lodar Owners Manual" provided herewith: no other express Warranty is made in respect to the Lodar. If any model or sample was shown to you, such model or sample was used for illustrative purposes only, and shall not be construed as a Warranty that the Lodar will conform to the sample or model.

Implied Warranties. The implied Warranty of merchantability and all other implied Warranties shall only extend from the provable date of purchase for two(2) years.

Some States within the USA do not allow limitations on how long an implied Warranty lasts, so the above limitation may not apply to you.

Incidental and Consequential Damage. Subject to the Sellers Limited Warranty obligations set forth herein, the Seller shall not be responsible for incidental damages of any kind, or for consequential damages to property, loss of profits and loss of use which may be caused by any fault in, or malfunction, or failure of the enclosed Lodar. Some States within the USA do not allow the exclusion or limitation of incidental or consequential damages, so the above limitation may not apply to you.

Condition of Warranty. The Seller shall not be required to comply with its Warranty duties provided herein if the fault, malfunction or failure of the Lodar was caused by damage (not resulting from faulty or malfunctioning components) or unreasonable use by you. Unreasonable use shall include, but not be limited to, the failure to provide reasonable and necessary maintenance or installation or use of the Lodar without compliance with the instructions contained in the Lodar Owners manual. Sellers liability under this Warranty or for any loss or damage to the Lodar product shall not exceed the cost of correcting the defects in or replacing the Lodar product, and upon expiration of the Warranty period, all such liability shall terminate. The agents, distributors and employees of the Seller are not authorised to make modifications to this Warranty, or additional Warranties binding on the Seller. Accordingly, additional statements, whether oral or written, do not constitute Warranties and should not be relied upon.

Legal Remedies of the Buyer

This limited Warranty gives you specific legal rights, and you may also have other legal rights, which may vary from State to State within the USA and from country to country. You also have implied Warranty rights. In the event of a problem with Limited Warranty service or performance, you may be able to go to a small claims court, a state court or a federal district court in the USA or to appropriate jurisdictions outside the USA.

Enquiries

Any enquiries regarding compliance with Warranties provided herein may be addressed in writing to:
Skidmore 4WD Limited, 60 Sandwell Street, Walsall WS1 3EB, England.

We, Skidmore 4wd Ltd., 60 Sandwell St., Walsall. WS1 3EB England.

Declare under our sole responsibility that the product:

Product Details	Name	- Lodar
	Series	- 92
	Type	- 92 x 16

To which this declaration relates is in conformity with the essential requirements and other relevant requirements, and is compliant with the standards and/or other documents, of the following directives :

EN 301 489-3	
R&TTE	(1999/5/EC)
Safety	Low Voltage Directive 300.683
EMC	2004/104/EEC ETSI 300-220 v1.1.1
Automotive EMC	Approval Granted - e11*72/245*95/54*3087*00
FCC	Approval Granted
Spectrum	433.92 MHz F1D (EUROPE (CE)) 418.0 MHz F1D (USA)

Please note that this certificate only covers Lodar and not the installation

Martin Skidmore	Position	Date
	CEO	September 2009

F.C.C. PART 15 INTENTIONAL RADIATOR MANUAL STATEMENT RADIO FREQUENCY INTERFERENCE STATEMENT

Note, this equipment has been tested and found to comply with the limits for an intentional radiator, pursuant to Part 15, subpart C of the F.C.C. Rules. This equipment generates uses and can radiate radio frequency energy. If not installed and used in accordance with the instructions, it may cause interference to radio communications.

The limits are designed to provide reasonable protection against such interference in a residential situation. However there is no guarantee that interference will not occur in a particular installation. If this equipment does cause interference to radio or television reception, which can be determined by turning the equipment on and off, the user is encouraged to try to correct the interference by one or more of the following measures:

- Reorient or relocate the receiving antenna of the affected radio or television
- Increase the separation between the equipment and the affected receiver.
- Connect the equipment and the affected receiver to power outlets on separate circuits.
- Consult the dealer or experienced radio/TV technician for help.

MODIFICATIONS

Changes or modifications not expressly approved by Skidmore 4wd Ltd. could void the users authority to operate the equipment