

92 Series – FET System 40 Functions and IP Transmitter with Shift Function

SYSTEM PART NUMBER

92 3 40 2 x 20 Function Receivers & 1 x 20 Function IP Transmitter with Shift Buttons.
Operating with a 20F IP Transmitter

REPLACEMENT TRANSMITTER

92 3 40TX 40 Function IP Transmitter with Shift Buttons.
Operating with a 20 Function IP Transmitter



SYSTEM CONTENTS

- 1 x IP Transmitter with Shift Function
- 1 x Lanyard
- 2 x Receivers with 3 x glands each
- 2 x External Aerial Kit (3m cable with gland)
- 1 x Instructions

IP TRANSMITTER SPECIFICATION

SWITCH - Type	Tactile Dome on PCB Keypad	
BATTERY - Type	4 x AAA Alkaline Manganese in holder (6 Volts)	
INDICATOR	2 x Red LED	
Transmitter Off	The STOP Button has been pressed and released	
Transmitter Slow Flash	ON and ready for use. The SET Button has been pressed and released	
Transmitter On	Transmitting. A STOP, SET or FUNCTION Button is being pressed	
Transmitter Fast Flash	Transmitting. An Indication that the battery will need replacing soon	
Enclosure Slow Flash	ON and ready for use with Receiver 2. The SET button has been pressed and released	
CURRENT DRAW		
Quiescent	20 micro amps	
Operating	25 milliamps	
PROTECTION		
Reverse polarity	Protected	
IP Rating	67	
Registration codes	Over 16 million	
PERFORMANCE		
Temp Range	-10° C to + 40° C (13° F to + 104° F)	
Range Nominal as supplied	60 metres (200 ft) from the Receiver, when driving a momentary output without signal drop out	
Transmitted power	1mW Typical	
COMPLIANCE		
EMC	2004/104/EEC	Exceeds ETSI 300 220
Modulation	FM	
Frequencies	418 MHz F1D	USA (optional UK)
	433.92 MHz F1D	World wide (optional USA)

RECEIVER SPECIFICATION

SWITCH TYPE

Output Switching MOS Field Effect Transistor (P Channel Power MOSFET)

SUPPLY VOLTS

Nominal 12/24 Volts DC
 Absolute Maximum 40 Volts DC
 Minimum 8 Volts DC
 Output Switch Supply Internal 12/24 Volts

AMPS

FET Rating 15 Amps
 System Rating 15 Amps
 Quiescent Current 25 mA on Standby (Not SET)
 Overload Protection 15 Amps (Auto Shutdown)

AERIAL

Internal Antenna Yes Supplied and fitted
 External Antenna Yes Supplied as an alternative option

OUTPUTS

Master 1 Can be Parallel or Continuous
 Function 40 20+20
 Master (Secondary) 1 Continuous

CONFIGURATION

RS232 Programming to users requirements Yes Not all models, see Build Specification Table. For programming interlocks, push/push latch, parallel master inhibit, timeout, channel timeout delay, master on delay, radio button de-latching and output allocation.

PERFORMANCE

Simultaneous Outputs Yes With horizontal interlocks (Interlocks are programmable – see CONFIGURATION above)
 Instant TX response Yes No perceivable delay between TX operation and RX action

DIAGNOSTICS

LED's Yes Confirm 5 Volts, SET, Fault and all Outputs.

PROTECTION

ESR Safety Yes See ESR Safety document.
 Back EMF Yes Diode protected on all outputs
 Registration codes Over 16 million
 STOP Connection Yes Internal Emergency Stop Connection

WIRING

Wiring Loom No Can be supplied as an option
 Cable Gland Yes Supplied – fitted by customer
 Connections Screw terminal into plug and socket on PCB, for easy "swap out"

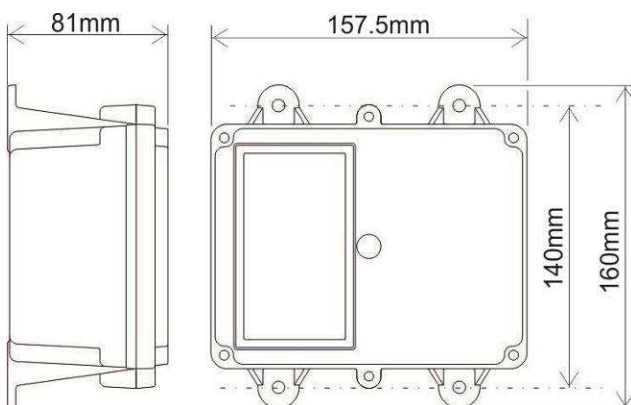

ENCLOSURE

Weight Approx. 0.5 lbs (335gms)
 Lid Clear PVC - to view LEDs
 Base Black PVC
 Breather "Gortex", fitted in the base
 Mounting 4 external lugs
 Fixings 5mm (3/16") not supplied
 IP Rating Performs to IP67 standard
 (0.5 metre water for 1 hour)

92 Series			92 3 36	92 3 40
BUILD SPECIFICATION TABLE FOR MODELS IN THIS RANGE				
Ident	Legend	Connection		
	+ -	Positive, Negative,	S	S
	M, F1, F2, F3	Master F1, F2 and F3	S	S
	F4, F5, F6, F7	F4, F5, F6 & F7	S	S
	F8, F9 & F10	F8, F9 & F10	S	S
	F11, F12, F13, F14	F11, F12, F13 & F14	S	S
	F15, F16	F15 & F16	S	S
	F17,F18,F19,F20	F17,F18,F19,F20	S	S
	S+, S-	Safety Solenoid S+ and S-	S	S
	STOP, 0Volts	STOP connections	S	S
	ANT	Internal Antenna	S	S
		SMA (external antenna)	S	S
LK1	LK1	Master - Parallel	C	C
LK2	LK2	Master - Continuous	C	C
	RS232	RS232	S	S
		9863 Antenna with 3 metre cable	2	2
		Number of Receivers	2	2
		Number of Transmitters	1	1

S = Standard. C = Customer configured (see "Factory Settings").

+ Positive 12/24 Volt supply
 - Negative 0 Volts
 F1 to F16 Outputs to F1 through F16
 M Master Output

 STOP - STOP, when grounded shuts down the Receiver
 S+ S- Master Secondary for Safety solenoid connections etc.
 ANT Blade connector for internal antenna
 SMA Aerial connection for optional external antenna (internal antenna must be removed)

 LK1 Master Selection by Jumper (BA = Continuous & AC = Parallel)
 LK2 Connected when using Parallel Master, connects safety circuits
 Factory Settings 418MHz configured Parallel, 433.92MHz configured Continuous
 LK3 RS232 for interface to access special programmes

RECEIVER PCB – Not to scale

Connector side

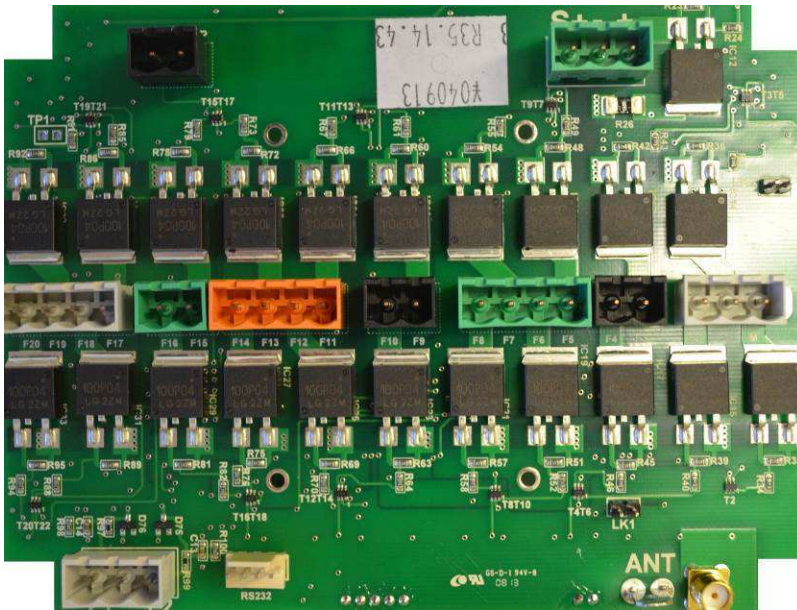

RECEIVER PCB – Not to scale

PCB component side

LED's are visible for confirmation that the system is operating correctly.

These are:-

- +5V Power Supply OK
- SET Receiver operational
- Fault Flashes for 20 seconds, on "power up", creating an open window for coding
- Fault ON = Current overload

An Output is signified when LED's F1 to F16 and Master are ON

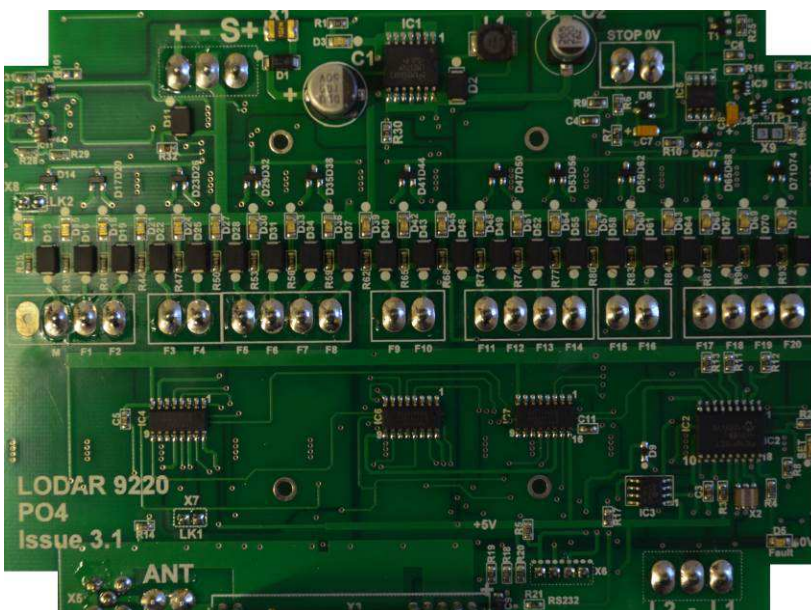

EXPLANATION OF “SHIFT” OPERATIONS - as illustrated with a 20 Function Transmitter.

These “SHIFT” operations can be applied to ALL Transmitters. For example, a 10 function Transmitter will give 20 functions – ideal if you do not want the larger 20 function Transmitter.



To operate 2 x 20 function Receivers, giving 40 functions

This is a standard 20 function Transmitter, modified so that it transmits 20 functions in two different modes.

The Green SET Button is the SHIFT button. Both 20 function Receivers can therefore be operated by one Transmitter.

Press the Green SET Button to turn both Receivers on - it will start in mode One; press it again for mode Two; press it again for mode One, and so on.

Press the Red Stop button to turn both modes off.

Receiver One (functions 1 to 20) is operated with the SHIFT buttons in mode One, indicated when the **Keypad LED** is flashing during operation.

Receiver Two (functions 21 to 40) is operated with the SHIFT buttons in mode Two, indicated when the **Enclosure LED** is flashing during operation.

To register a Transmitter to its TWO Receivers.

Switch OFF or DISCONNECT the power to the Receivers.

Switch ON or Reconnect the power to Receiver ONE, this opens a **10 SECOND** registration window in its processor.

Immediately **PRESS** and **HOLD** the green **SET** button while the registration window is open until the **SET** LED lights (5 seconds), the **SHIFT** function must **NOT** be active.

Receiver TWO, repeat the process but this time **PRESS** and **HOLD** the **SHIFT** button, and **PRESS** and **HOLD** the **SET** button until its **SET** LED lights.

You have now coded the Transmitter to both receivers.