

CAUTION Take care to maintain alignment

IMPORTANT MEASUREMENT - 240mm (9.5")
Distance between mount face for trunnion and Lug for clevis when lever is in neutral position (see figure 2)
This is to ensure cylinder is at mid point and can operate in both directions

IT IS BETTER FOR THIS DISTANCE TO BE LONGER NOT SHORTER TO ALLOW FOR PACKING IF REQUIRED

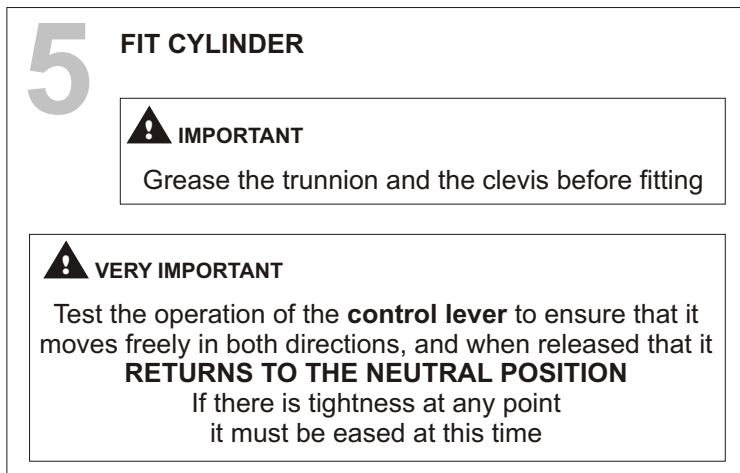



Part Number
9900 - 12 Volt
9901 - 24 Volt

6 IDENTIFY POWER CONNECTION POINT AND ISOLATE SUPPLY

Remove fuse

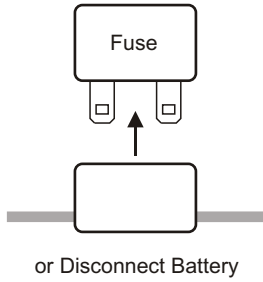

10 ACTIVATE SUPPLY

Replace fuse

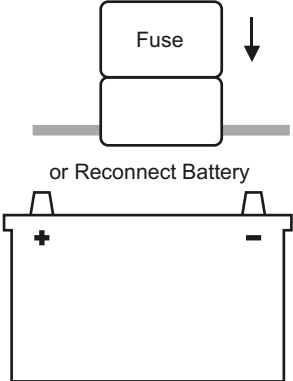

YOUR LODAR SHOULD NOW BE WORKING

CONTACT INFORMATION

Skidmore 4wd Ltd
60 Sandwell Street
Walsall WS1 3EB
England

Tel. +44 (0)1922 613633
Fax. +44 (0)1922 626991

Email sales@lodar.com

www.lodar.com

7

WIRE YOUR LODAR 8000 or 9100 TO THE ACTUATOR CONTROL UNIT

NOTE - Power for Lodar is drawn from the actuator control and power for both units is fed to the actuator control box

Secure using 5mm (3/16") bolts (not supplied) through the 4 mounting feet

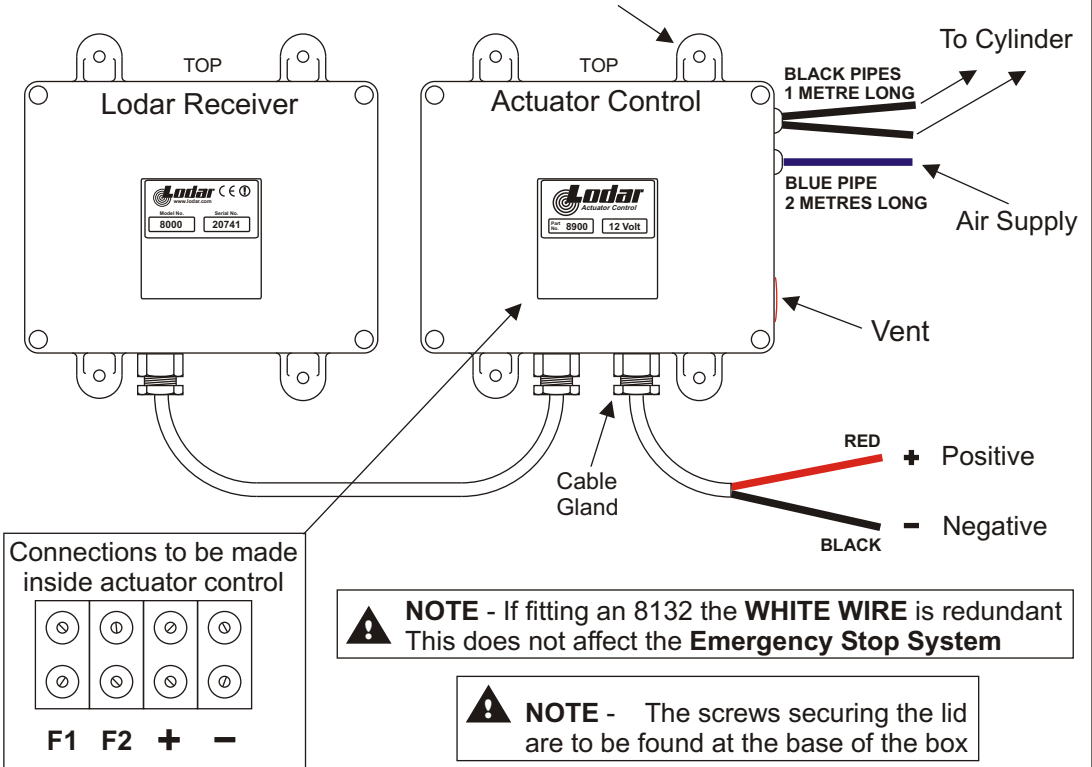

8

MOUNT THE LODAR RECEIVER AND ACTUATOR CONTROL (see figure 7 for mounting points) WITHIN 1 METRE OF CYLINDER

NOTE - Refer to Lodar instructions for best position to mount receiver

9

BEFORE YOU MAKE FINAL CONNECTIONS

CAUTION - Maximum air pressure 120 psi

IMPORTANT - Take care to keep all pipes and connectors clean at all times **PARTICLE INGRESS WILL CAUSE DAMAGE**

CAUTION - A pressure regulator may be required At 120 psi the cylinder can push with a force of 91 lbs and pull 76 lbs

CAUTION - Air supply should be **CLEAN** and **DRY** at all times. Most important in cold climates - Actuator failure could occur

FINAL CONNECTIONS

CONNECT to power supply (see figure 7)

CONNECT to air supply (BLUE PIPE) an adaptor may be require (not supplied)

CONNECT to cylinder (BLACK PIPES) all pipes are push fit

CAUTION - DO NOT pressure wash the RED vent plug as this could cause water ingress and damage the air valves

11

FINAL ADJUSTMENTS

There is a flow control valve on the blue pipe in the Actuator Control Box. Screw the adjuster in (clockwise) to reduce the airflow into the cylinder. This gives some degree of "feel" and "soft start" to the system.